

USER MANUAL

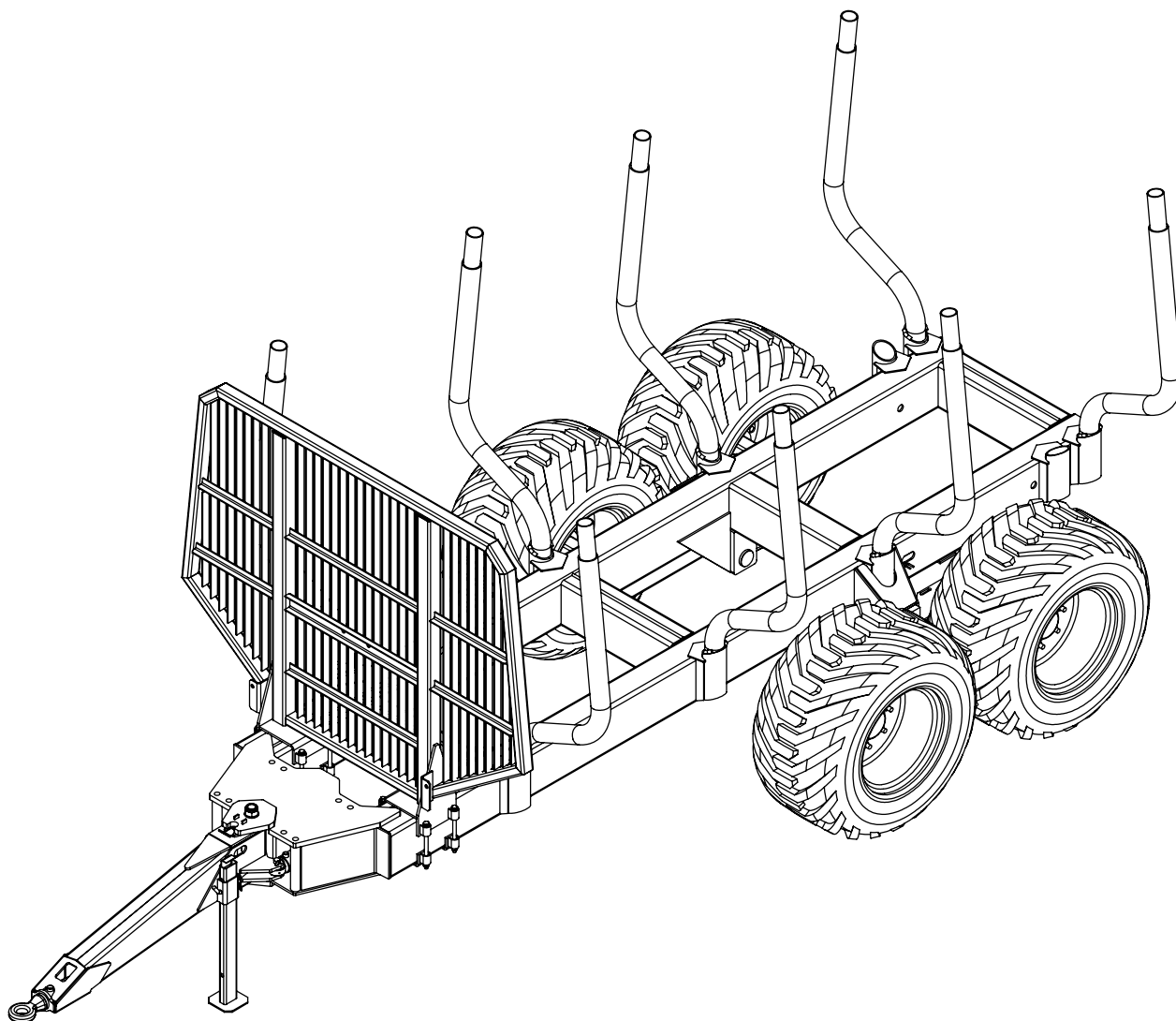

FOREST TRAILER PALMS 15D

TABLE OF CONTENTS

| | | |
|-----|-----------------------------|----|
| 1. | INTRODUCTION | 2 |
| 2. | SAFETY..... | 3 |
| 3. | BASIC COMPONENTS | 5 |
| 4. | ACCESSORY | 6 |
| 5. | TECHNICAL DATA | 7 |
| 6. | HYDRAULIC SYSTEM..... | 9 |
| 7. | ASSEMBLY AND MOUNTING..... | 10 |
| 8. | OPERATING INSTRUCTIONS..... | 12 |
| 9. | STORAGE INSTRUCTIONS | 13 |
| 10. | MAINTENANCE | 14 |
| 11. | SPARE PARTS | 15 |
| 12. | WARRANTY | 17 |

1. INTRODUCTION

This manual gives you detailed overview about forest trailer **Palms 15D**. Read the manual carefully before you start using this machine. The manual contains essential directions for efficient and safe use of forest trailer. These instructions should always be followed.

This forest trailer is constructed to transport raw wood material from forest as well for transportation treated wood. Forest trailer is build for use with agricultural tractors. It has an unified connection junction for mounting Palms forest cranes. This machine meets all technical standards and safety regulations of valid EU Machinery Directive and its amendments. Forest trailer is fitted out with CE marking.

User of forest trailer is obliged to be aware of and strictly follow all safety precautions and instructions described in this manual. In addition to this, instructions of local occupational safety authorities, as well national laws, regulations and highway codes, must be followed. Using the machine for other tasks, than those for which it is intended or exceeding its performance, is not allowed. The manufacturer/dealer is not responsible for damage caused by misuse of the forest trailer.

Pay attention to regular maintenance. In case there will occur problems during use of forest trailer, which are not covered in this manual, contact authorized dealer or manufacturer.

2. SAFETY

2.1 General

Read the manual carefully before you start using forest trailer. Use forest trailer only for purposes, what it is made for. Driver must have proper valid licence to drive tractor in connection with trailer and has sufficient training for that. Notice, avoid and prevent all potentially hazardous situations.

IT IS STRONGLY FORBIDDEN:



- to use forest trailer in state of intoxication by alcohol, drugs or other psychoactive substances
- to exceed maximum loading values
- to use forest trailer for transporting people
- to rebuild forest trailer
- to use repairing materials without the producer's permission

BEFORE YOU START LOADING, MAKE SURE THAT:

- forest trailer is fully in working condition
- you have full visibility over all the working area
- forest trailer is placed on even ground
- parking brake is engaged

2.2 Safety distances

General safety distance for working with forest trailer is 20 metres!

Follow special safety distance when working close to live electrical conductors:

| Rated voltage, kV | Safety area, m |
|-------------------|----------------|
| Up to 0,5 | 2 |
| Up to 20 | 10 |
| 35 – 110 | 25 |
| 220 – 330 | 40 |

Table 1. Safety area

2.3 Hydraulic system



- Hydraulic system must be serviced by qualified and experienced hydraulics mechanic only
- Continually inspect the condition of hydraulic system. Repair all safety endangering defects immediately
- Before starting repair work or maintenance make sure, there is no pressure in hydraulic system
- Use safety goggles and gloves during repair work and maintenance
- Use original spare parts or parts recommended by the manufacturer
- Prevent oil dripping to the ground to avoid environment pollution
- In ecologically sensitive areas use bio-oil

2.4 Operation



- Ensure, that forest trailer is in good working condition
- Operating with damaged or defective machine is prohibited
- Ensure, that you have control over all the working area
- Prevent entering unauthorized persons to the working area
- Support legs must be used while forest trailer is being loaded
- Be sure not to endanger anyone while lowering the support legs
- Use parking brake while loading
- Do not load over the upper edge of safety screen
- Loading short logs be shure they are supported at least with two pairs of bolsters
- Follow strictly load limits stated by the manufacturer for certain trailer
- Pull the support legs up before moving forest trailer
- Release parking brake
- Pay extra attention driving with unlocked drawbar
- Prevent any hoses between trailer and tractor to be squashed on sharp turns
- For driving on roads lock drawbar in straight position with locking shaft
- Make shure signal lights are unfolded and working for driving on public roads
- Follow traffic regulations
- Max speed by manufacturer for certain forest trailer is 40 km/h
- Manufacturer is not responsible for damage or loss, caused by misuse or incorrect, careless and inappropriate use of the machine

3. BASIC COMPONENTS

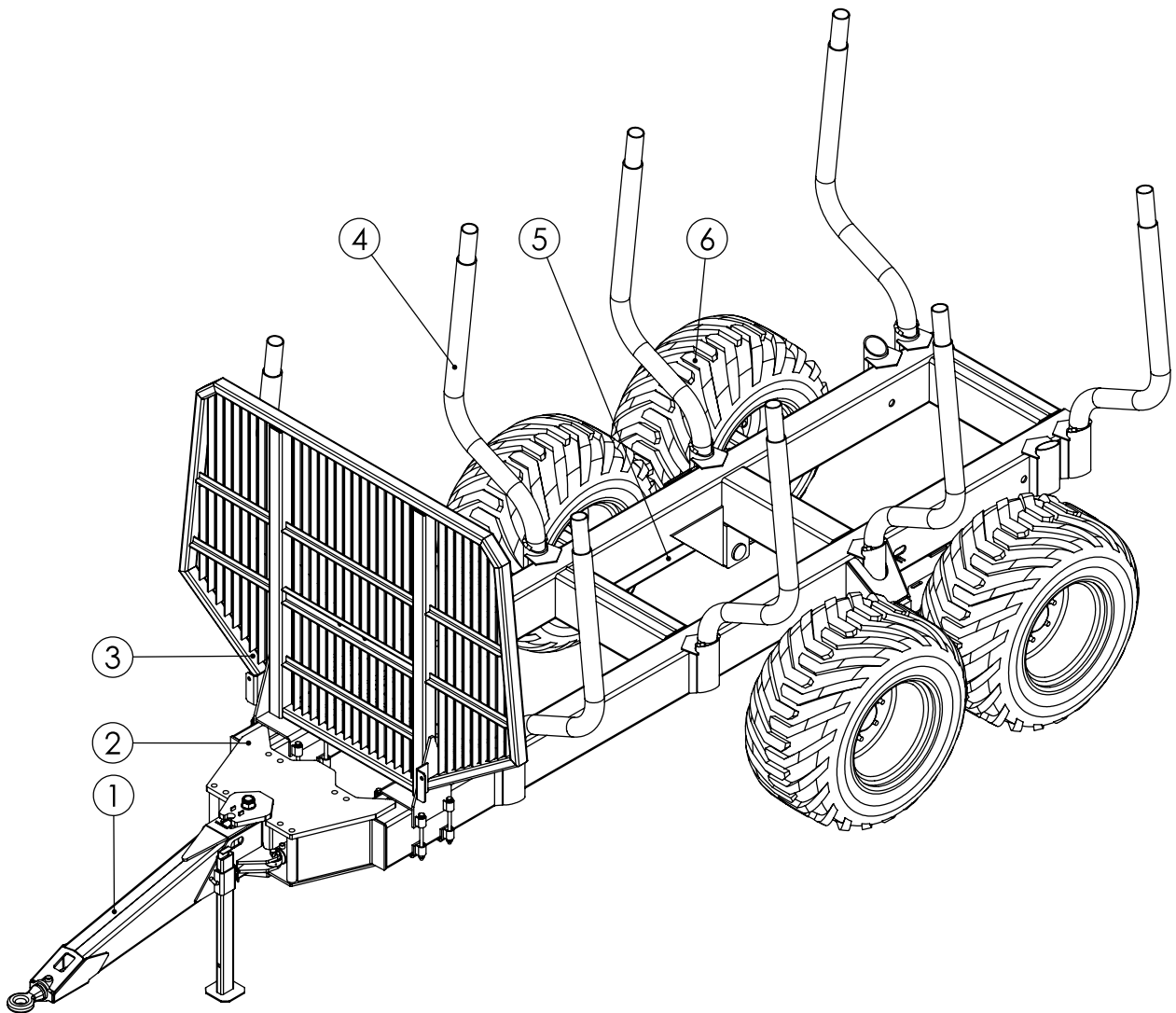

Figure 1. Basic components of Palms 15D forest trailer

1. Drawbar

2. Chassis

3. Safety grill

4. Bolster

5. Boogie

6. Wheel, standard 500/50-17

4. ACCESSORY

4.1 Brakes

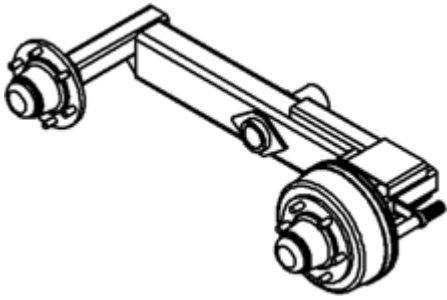

Figure 2. Brakes on on axle

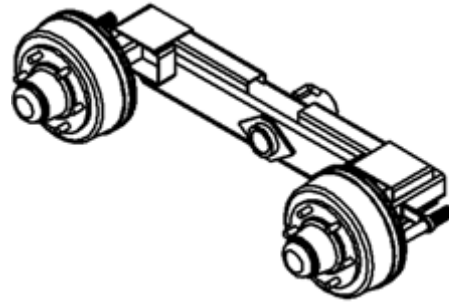

Figure 3. Brakes on two axles

4.2 Frame extension and signal lights

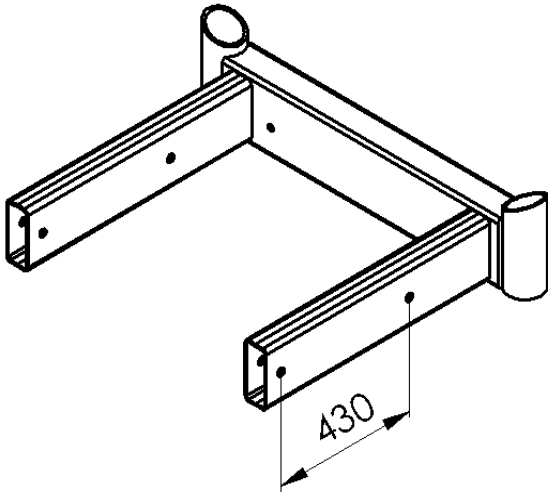

Figure 4. Frame extension

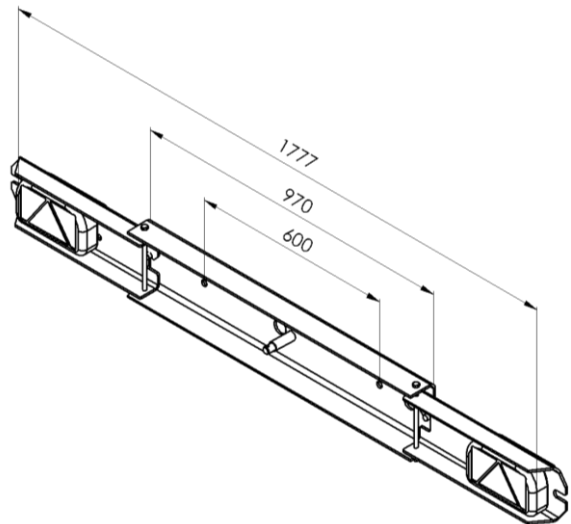

Figure 5. Signal lights

5. TECHNICAL DATA

5.1 Technical data

| | |
|--|---------------------------|
| Max payload, kg | 15 000 |
| Axles, mm-bolts | 80x80-8 |
| Chassis | 2x(250x150x8) |
| Loading area, m ² | 3 |
| Length of loading area, mm | 4180 |
| Total length, mm | 6425 |
| Brakes option | Hydraulic or pneumatic |
| Width with standard wheels, mm | 2535 |
| Standard wheels | 500/50-17 |
| Drawbar cylinders | 2 |
| Drawbar turning angle to sides, ±° | 40 |
| Net weight, kg | 2635 |
| Max lifting torque of installed crane, kNm | ≤62 |

Table 2. *Forest trailer Palms 15D technical data*

Manufacturer reserves the right to change specifications without prior notice.

5.2 Dimensions

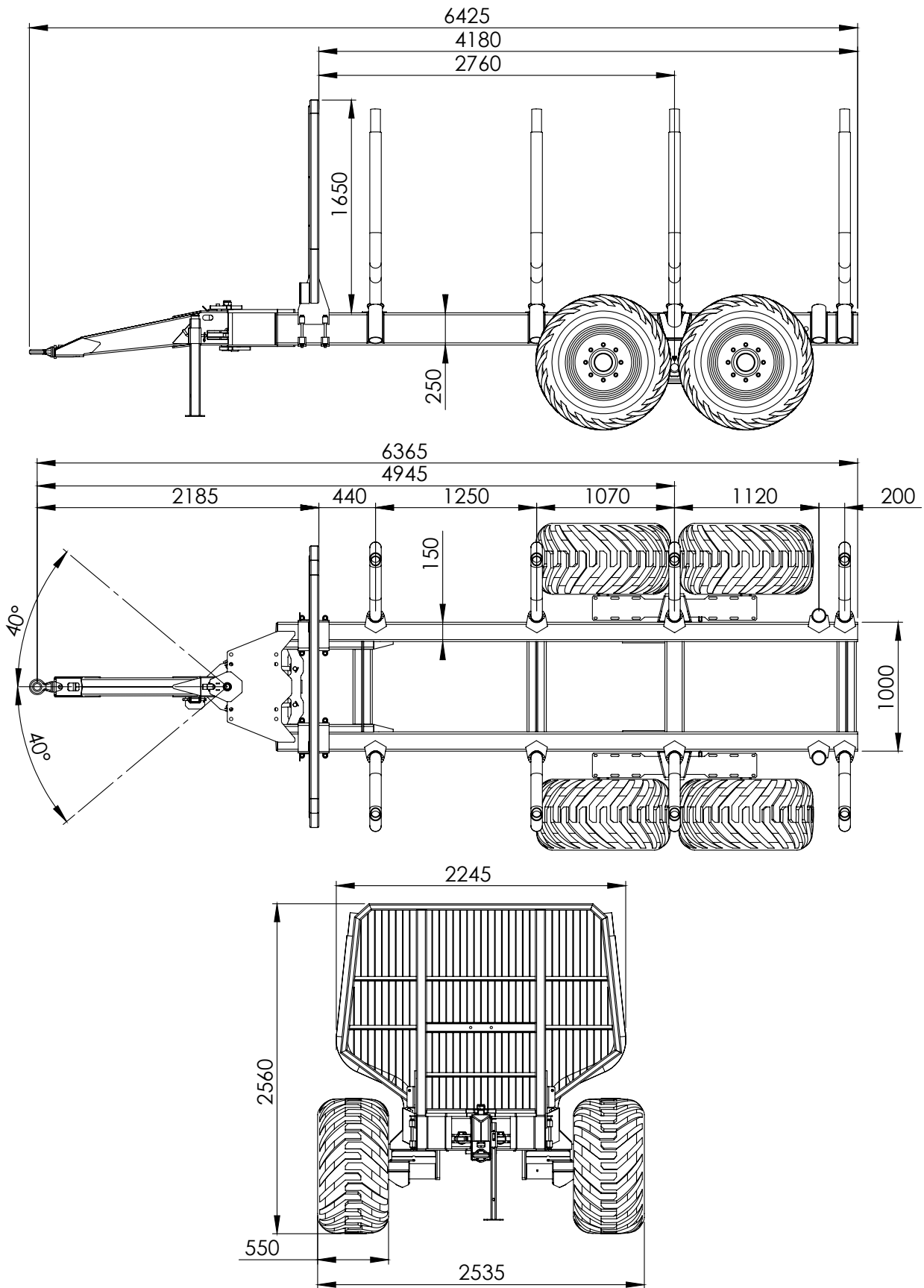

Figure 6. Dimentions of Palms 15D forest trailer

6. HYDRAULIC SYSTEM

6.1 Connection

Connect trailer's hydraulic hoses to one of sections of tractor's control valve. Be sure all connections are properly locked. Unlock drawbar by removing locking shaft. Using lever of control valve section, where you connected forest trailer's hydraulic hoses, work carefully thru extreme positions of drawbar to both sides until turning cylinders are working smoothly.

ASSEMBLY AND MOUNTING

Read these instructions before starting any assembly or mounting work. Improper mounting can cause hazards during use of the forest trailer. Mounting, carried out in a manner other than specified in this manual, can expose the user to danger and will void the manufacturer's warranty.

6.2 Mounting forest crane to Palms trailer

Mounting of forest crane should be performed at the dealer service center or by person authorized by the manufacturer or dealer. Mounting/detaching the crane can also be made by end user, if professional equipment is used, all safety regulations are followed and at least one qualified mechanic is in present during all the mounting/detaching process.

Strength class for mounting bolts of support legs - trailer (pos. 1, fig. 5) has to be 12.9 (DIN912). Use self-locking nuts M24. Tightening torque for the mounting bolts is 1220 Nm.



Retighten bolts after test run and after first 8 hours of use! Check after 40 working hours, tighten if needed. Later on do visual check.

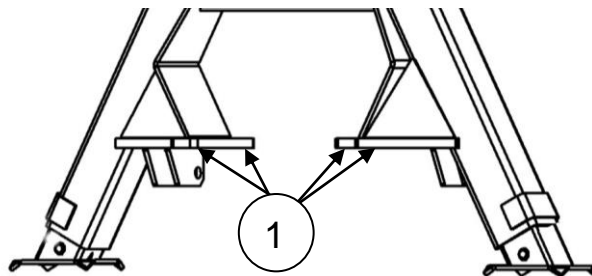
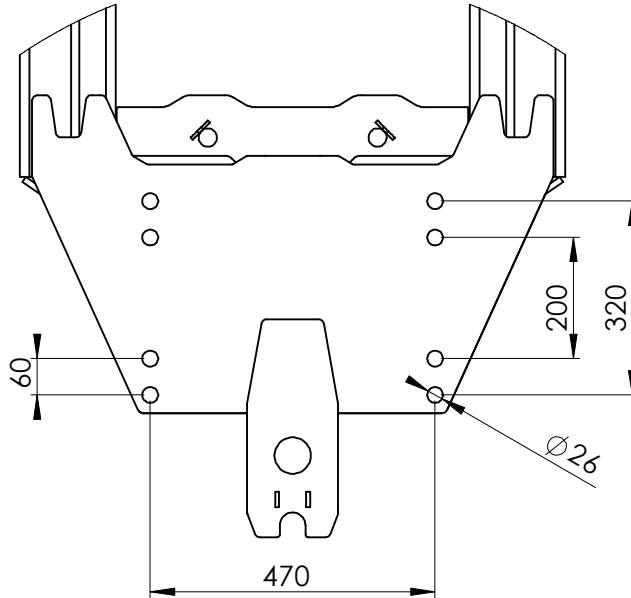

Figure 8. Connection junction on A- support legs

Old



New

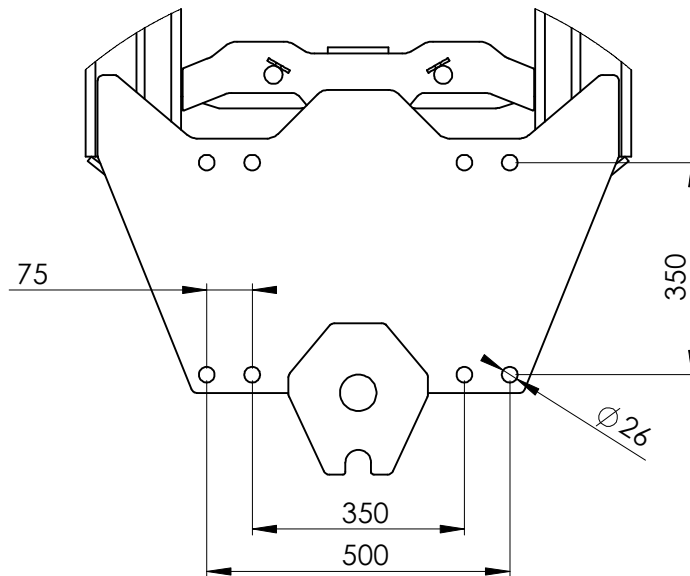

Figure 9. Mounting plate

7. OPERATING INSTRUCTIONS

7.1 Connecting forest trailer to tractor

Before you hook up trailer with tractor ensure, that:

- tractor is enough powerful for this trailer
- tractor's hitch is in perfect working condition
- trailer is on even ground and fixed with wheel chocks
- trailer is in perfect working condition
- all hydraulic hoses on trailer are properly connected

Before you start transport forest trailer ensure, that:

- forest trailer is hooked up and locked to tractor properly
- hydraulic hoses between trailer and tractor are connected properly
- trailer's brakes are released
- wheel chocks have been removed
- there is right air pressure in trailer's tyres
- drawbar is locked in straight position while driving on roads
- signal lights cable is connected to the tractor and lights are working properly



Adjust speed according to the road and weather conditions.

Driving with the load be especially careful on turns!

Do not exceed the speed limit!

8. STORAGE INSTRUCTIONS



Always switch the pump off before disconnecting hydraulic hoses from tractor's hydraulic system!

- Clean forest trailer and if necessary, touch up any points, where paint has peeled off
- Lubricate forest trailer thoroughly (see lubricating instructions)
- Release pressure from the cylinders
- Protect draw bar turning cylinder's piston rods with grease
- Store forest trailer in a sheltered area (under the roof), avoid direct contact with ground

9. MAINTENANCE

9.1 Lubrication

Using the appropriate lubricants like Beacon EP2, Multipurpose GR Moly, Mobilux EP2, Mobil Grease MP Special, Energrease LS-EP2 or similar. Right lubricants guarantee troublefree operation of the machine.

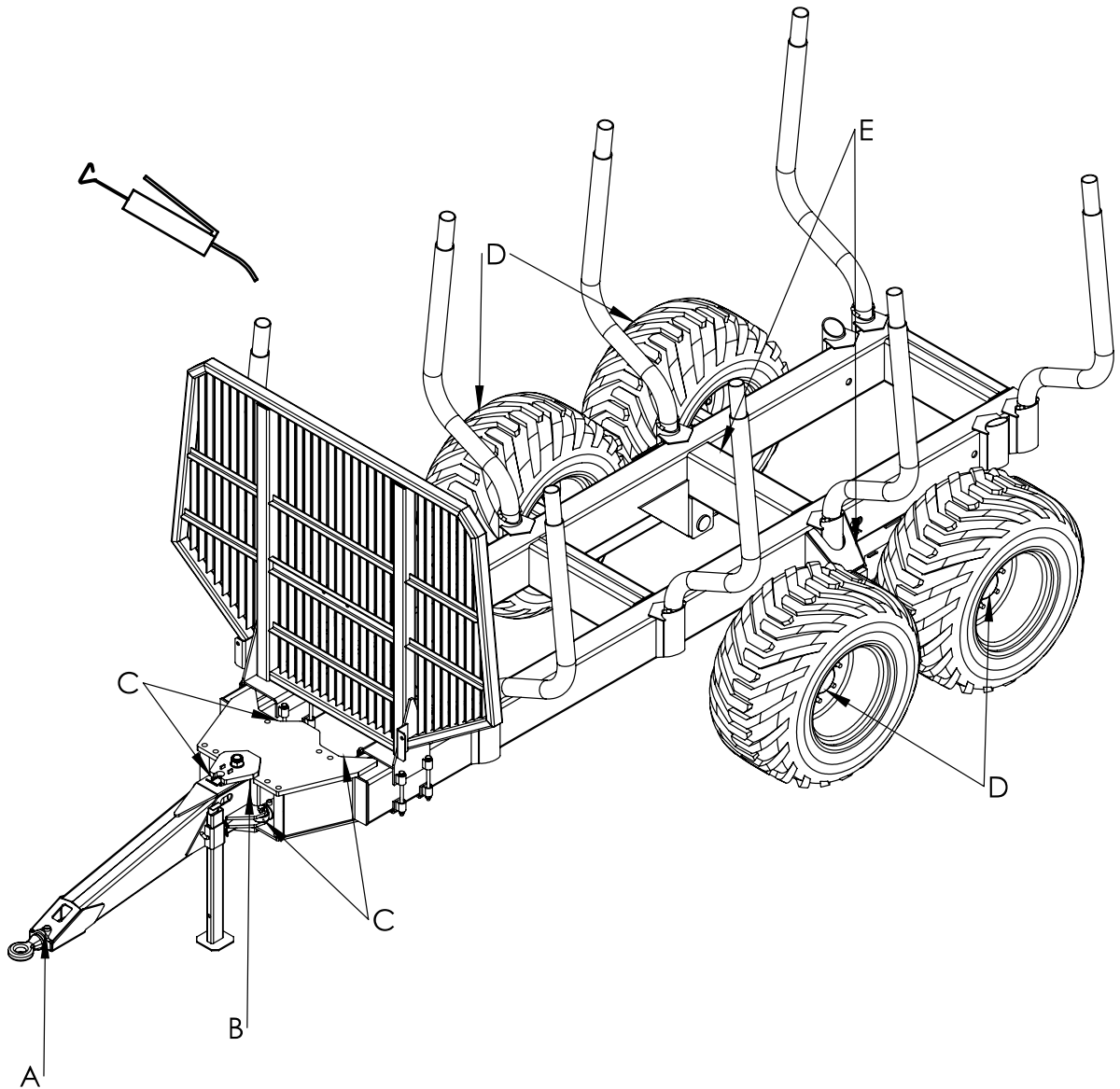

Figure 10. Lubrication points of Palms 15D forest trailer

| Lubrication point | Pcs | Lubricant | Interval, working hour | Additional information |
|--------------------------------|-----|-----------|------------------------|------------------------|
| 1. Drawbar eyelet, A | 1 | Grease | 8 | 2% molybdensulfide |
| 2. Shaft of drawbar, B | 1 | Grease | 8 | |
| 3. Turning cylinder eyelet, C | 2 | Grease | 8 | |
| 4. Rollerbearings of wheels, D | 4 | Grease | Once a year | |
| 5. Shaft of boggie, E | 2 | Grease | 8 | |

Table 3. Lubrication

10. SPARE PARTS

10.1 Basic parts

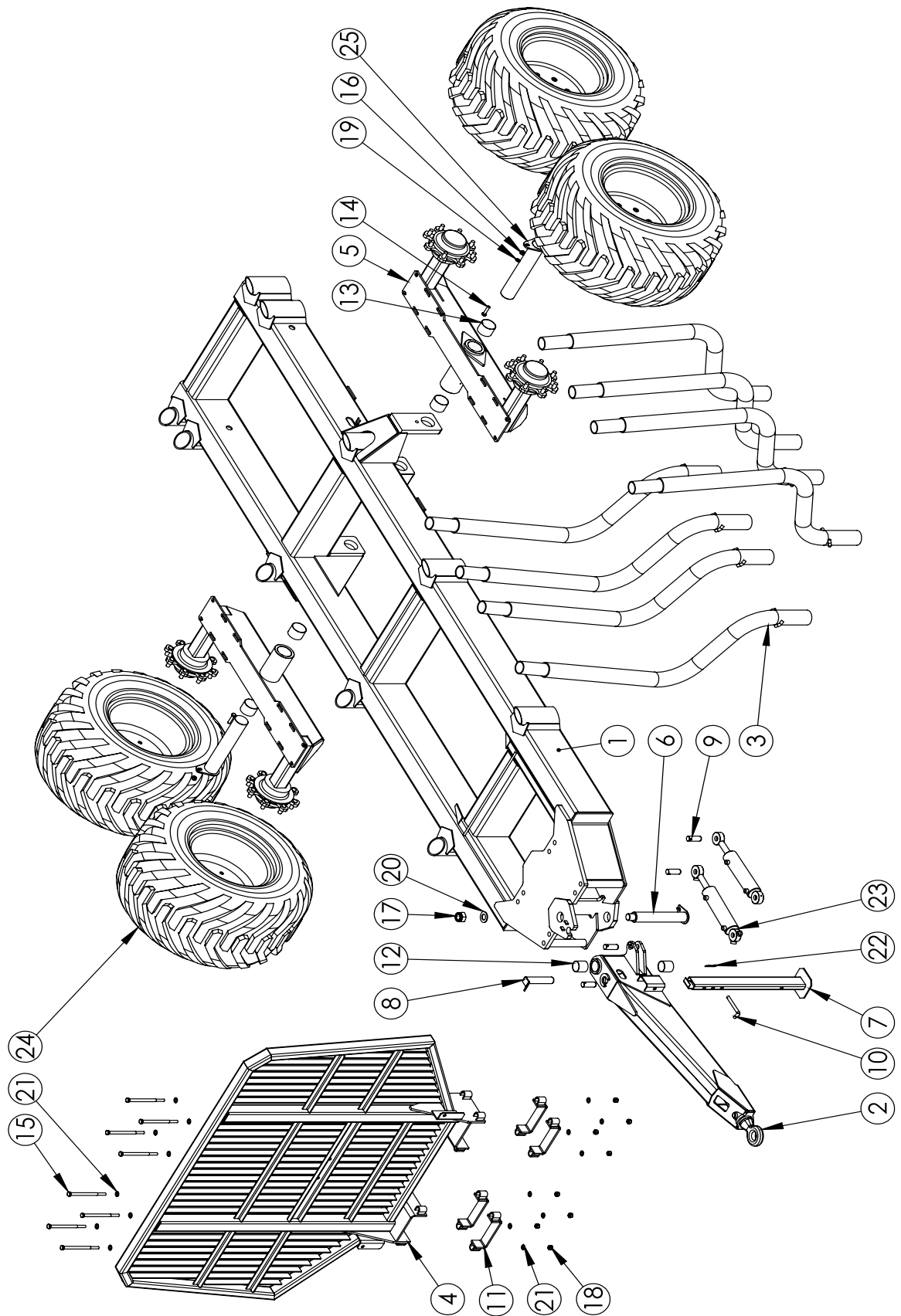

Figure 11. Spare parts of Palms 15D forest trailer

| Pos | Qty | Part № | Part name |
|-----|-----|---------------|-------------------------------|
| 1 | 1 | 15D.01.00.00 | Chassis |
| 2 | 1 | 15D.02.00.00 | Drawbar |
| 3 | 8 | 112.10.00.00 | Bolster |
| 4 | 1 | 142.04.02.00 | 15D Safety screen |
| 5 | 2 | 10.05.00.00 | Boogie |
| 6 | 1 | TK-60-340 | Shaft of drawbar |
| 7 | 1 | Park.I.L | Parking leg |
| 8 | 1 | tl.00 | Locking shaft of drawbar |
| 9 | 4 | SA-30-89 | Shaft of cylinder |
| 10 | 1 | tjs.01 | Locking shaft of parking leg |
| 11 | 4 | 142.08.00.00 | Clamp |
| 12 | 2 | L11FB0926060 | Bronze slide bearing 60 mm |
| 13 | 4 | L11FB09218060 | Bronze slide bearing 80x60 mm |
| 14 | 2 | M14x60b | Bolt M14 x 60 DIN 933 |
| 15 | 8 | M16x240b | Hex head bolt M16x240 DIN 931 |
| 16 | 2 | M14n | Nut M14 DIN 985 |
| 17 | 1 | M36n | Nut M36 DIN 985 |
| 18 | 8 | M16n | Nut M16 DIN 985 |
| 19 | 2 | M14w | Washer 14 DIN 125 |
| 20 | 1 | M30w | Washer 30 DIN 125 |
| 21 | 16 | M16w | Washer 16 DIN 125 |
| 22 | 1 | pin | Stopper pin |
| 23 | 1 | 70-32-200 | Drawbar turning cylinder |
| 24 | 4 | - | Wheel |
| 25 | 2 | T-80-415 | Shaft of boogie 80 mm |

Table 4. Spare parts list of Palms 15D forest trailer

11. WARRANTY

The machine shall not be taken into use before the operating manual is thoroughly read and understood.

Duration of warranty:

- Parts manufactured by Palmse Mehaanikakoda LLC, warranty is three years.
- Hydraulic components, sliding bearings, cylinders, rotators, pumps, valve blocks and all other parts and equipment not manufactured by Palmse Mehaanikakoda LLC, manufacturer warranty applies.

The warranty does not apply:

- to any faults or defects arising from normal wear, negligence or improper operation.
- to faulty installation or incorrect or inadequate maintenance.
- if during maintenance or repairs were not original or same quality level as originals spare parts used.

The warranty is invalidated:

- if any repairs or constructional changes to the warranted products have been made by others than the manufacturer or a service shop authorized by the manufacturer or if the equipment has been altered without co-ordination with manufacturer.
- if the settings of the pressure relief valves of the loader's directional control valves have been changed without co-ordination with manufacturer.

Palmse Mehaanikakoda LLC will be not responsible for any damages caused by the improperly handled machine.

The manufacturer will not assume any liability for any economical losses or for any consequential damage to persons or property, which may incur during product's usage or failure.

Product warranty is **NOT VALID** in case of user's incompetence and/or irrespective handling of the equipment. Warranty does not cover transportation cost, repairing labor or loss of profit due to normal abrasion or product failure.

Manufacturer:

Palmse Mehaanikakoda LLC

Võsupere

Lääne-Virumaa

45 202 Estonia

Tel +372 32 55 375

Fax +372 32 55 378

info@palms.eu

www.palms.eu